

# MARTY THE ROBOT

## — Build Guide —

# MARTY BUILD GUIDE

Thank you for adopting a Marty! This guide will help you put your Marty together.

Make sure to:

- Do the steps in order.
- Pay attention to the part orientation.
- Be gentle with the motors.
- Not over-twist the servo horns.
- Not trap or squish the cables.
- Get help from an adult if your under 14.
- Have fun!

**Top Tip:** Go to [robotical.io/getstarted](http://robotical.io/getstarted) for detailed written instructions.

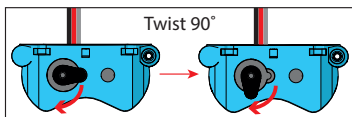
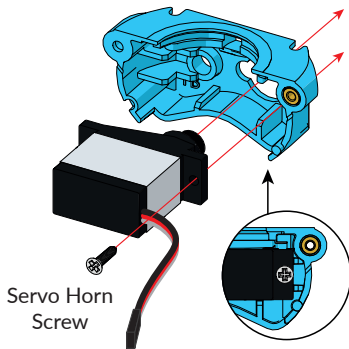
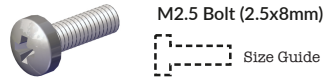

Build 2 assemblies — x 2

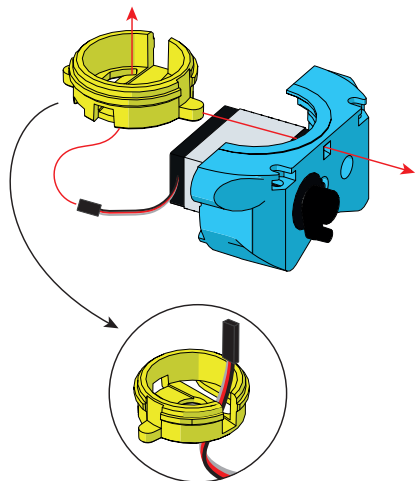
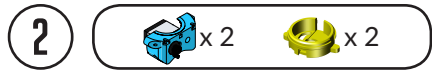

x 2





3

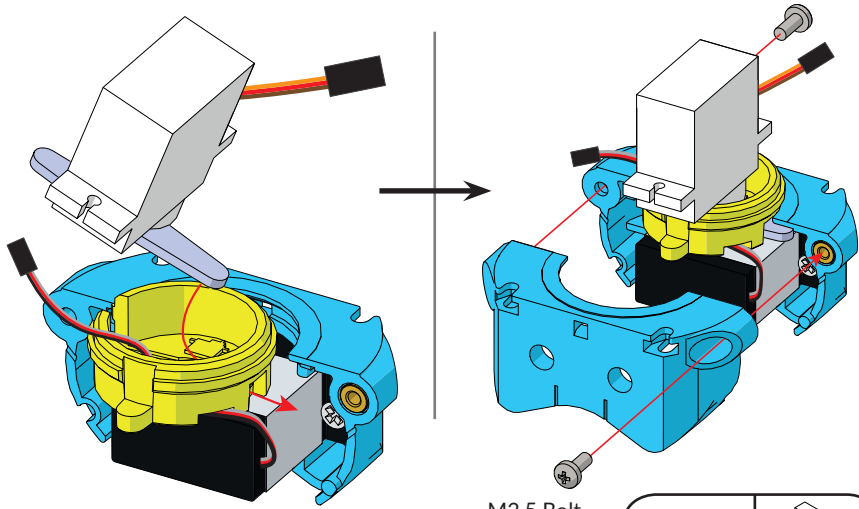

-  x 2
-  x 2
-  x 2
-  x 4



M2.5 Bolt

- x 2**
- 

4

-  x 2
-  x 4
-  x 4

 Be careful not to trap cables

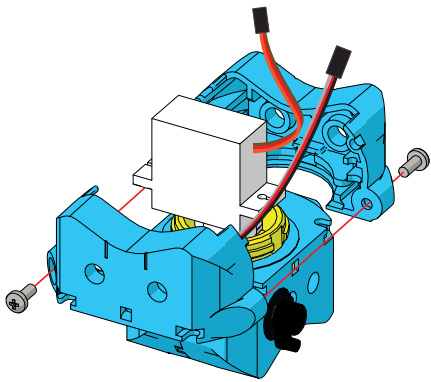

- x 2**
- 

5

-  x 2
-  x 2
-  x 4

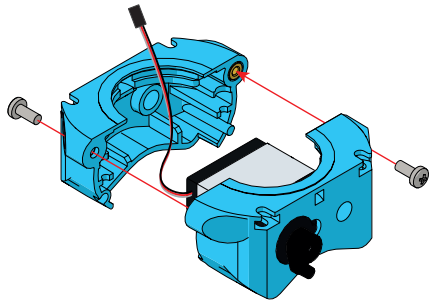

- x 2**
- 

6

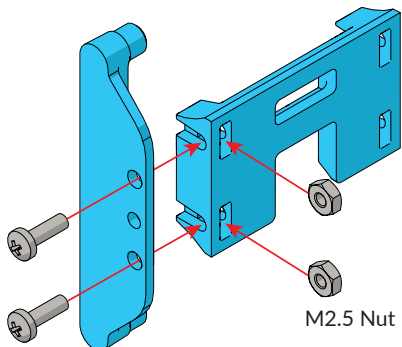
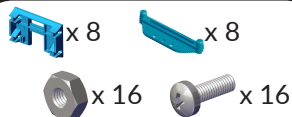

M2.5 Bolt

x 8



7

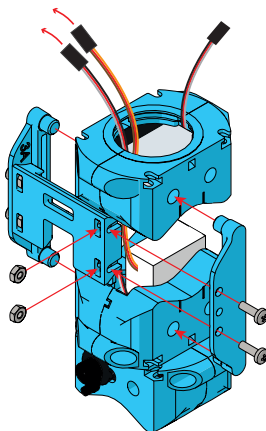
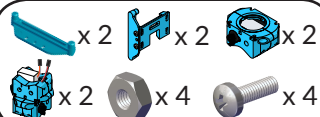

x 2



8

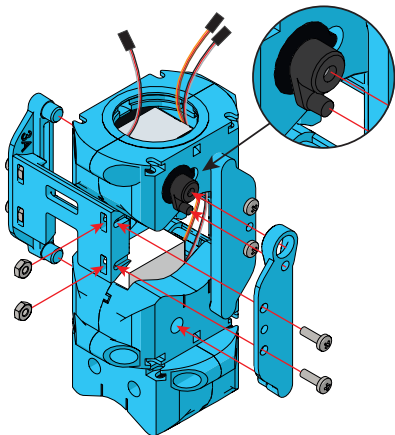
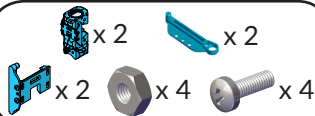

x 2





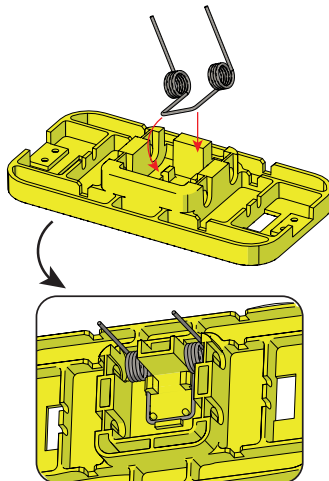

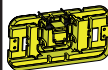

9





x 2



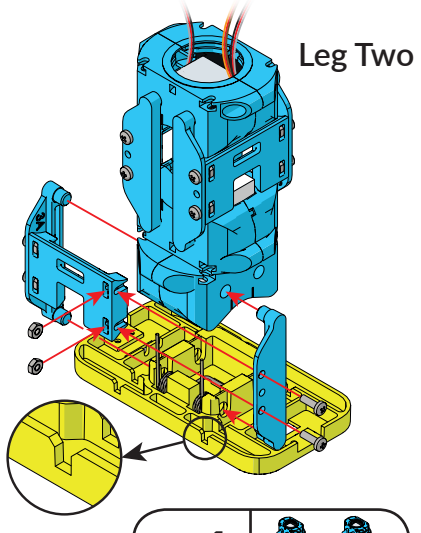
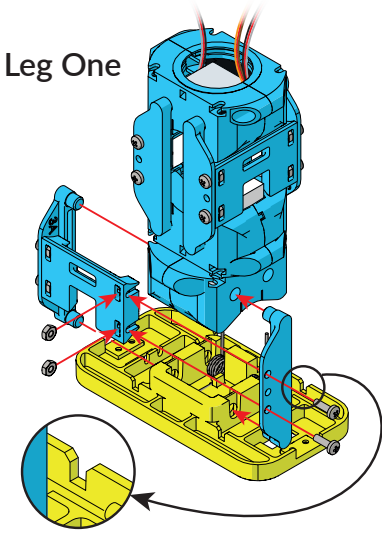





- 10  x 2  x 2  x 2  x 2  x 4  x 4



 Rotate foot 180° from Leg One to Leg Two

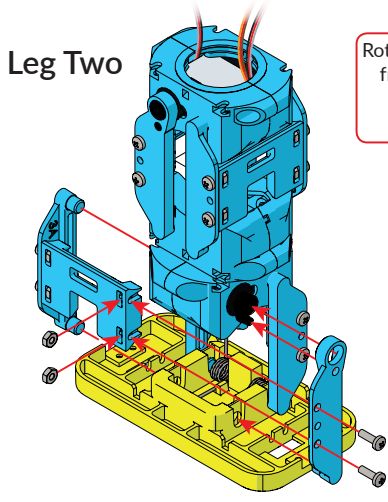

- x 1  

- 11  x 1  x 1  x 2  x 2  x 4  x 4

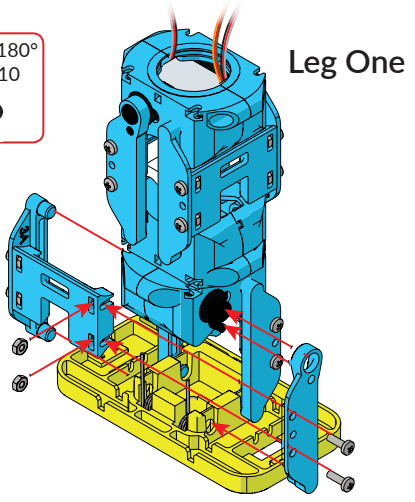

Rotate view 180°  
from Step 10

- x 1  

12

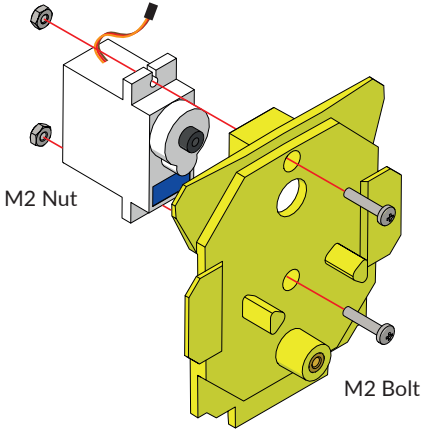
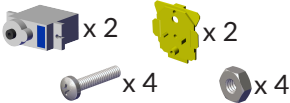

x 2



13

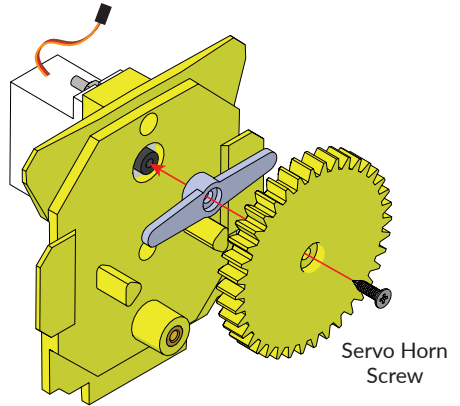

x 2



14

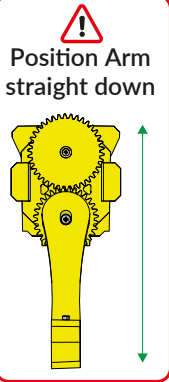
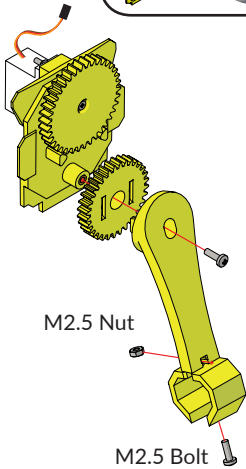

x 2



15

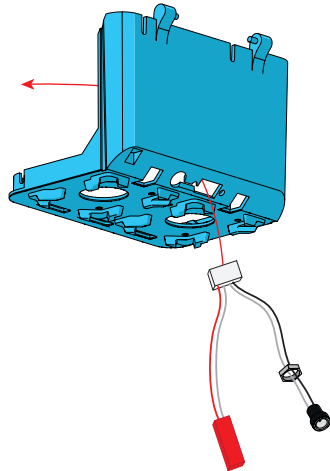

x 1



16

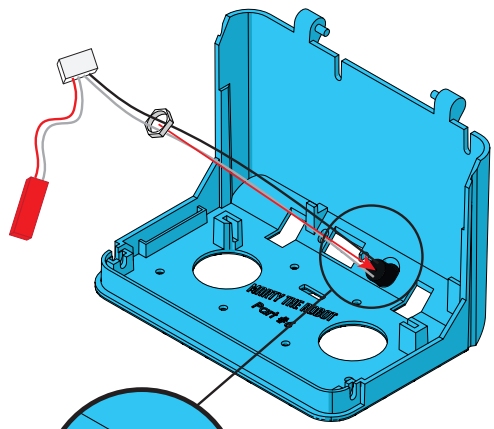
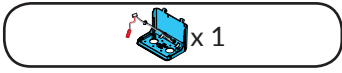

Push onto thread and finger tighten

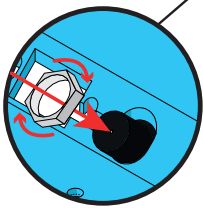

17

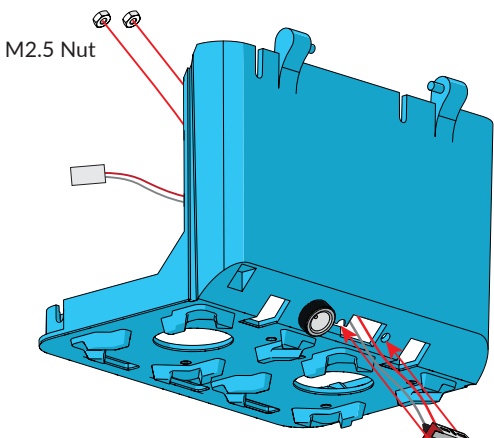
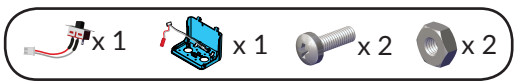

M2.5 Nut

M2.5 Bolt



18

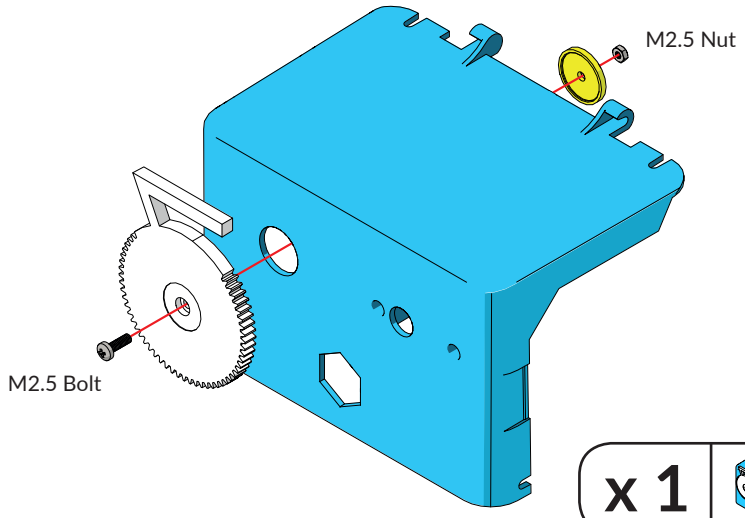
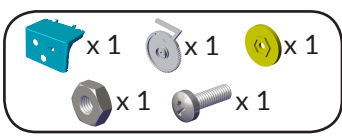

19

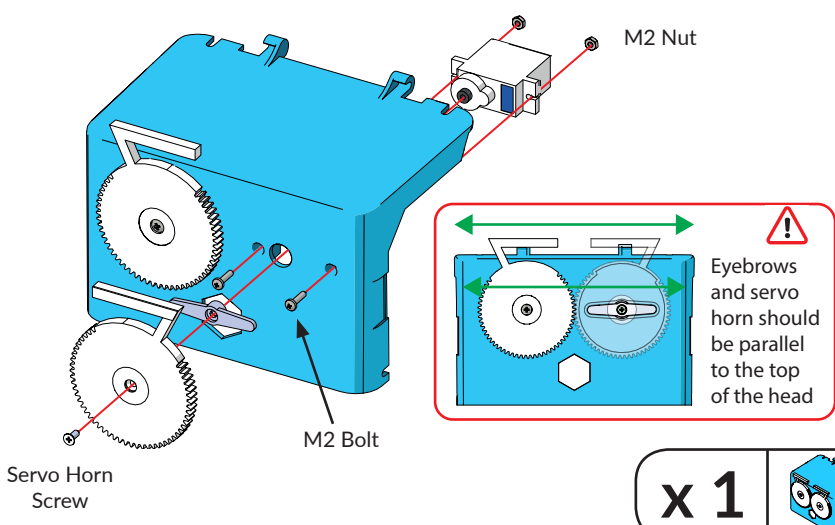
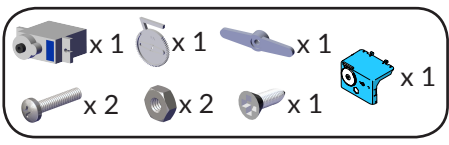

# HAVE YOU GOT ALL YOUR ASSEMBLIES?

Check that you have assembled all 6 parts of Marty.  
You should have:

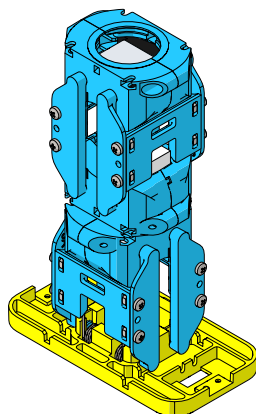
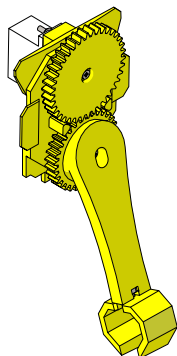
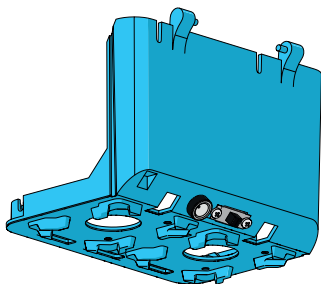
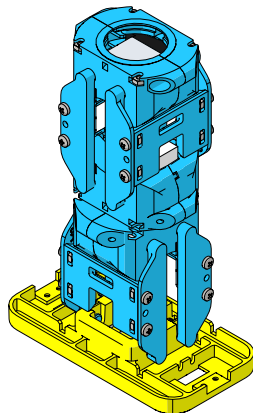
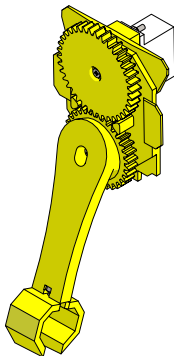
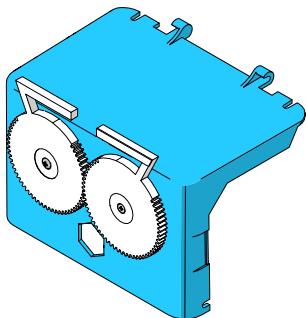

If in doubt, go to [robotical.io/getstarted](https://robotical.io/getstarted) for detailed written instructions and support.

# CHECK YOUR LEG ASSEMBLY

Check that you have assembled both of Marty's legs correctly and they resemble the image below.

Servo cables coming out the top

Hip Servos facing same direction

No servo cables visible



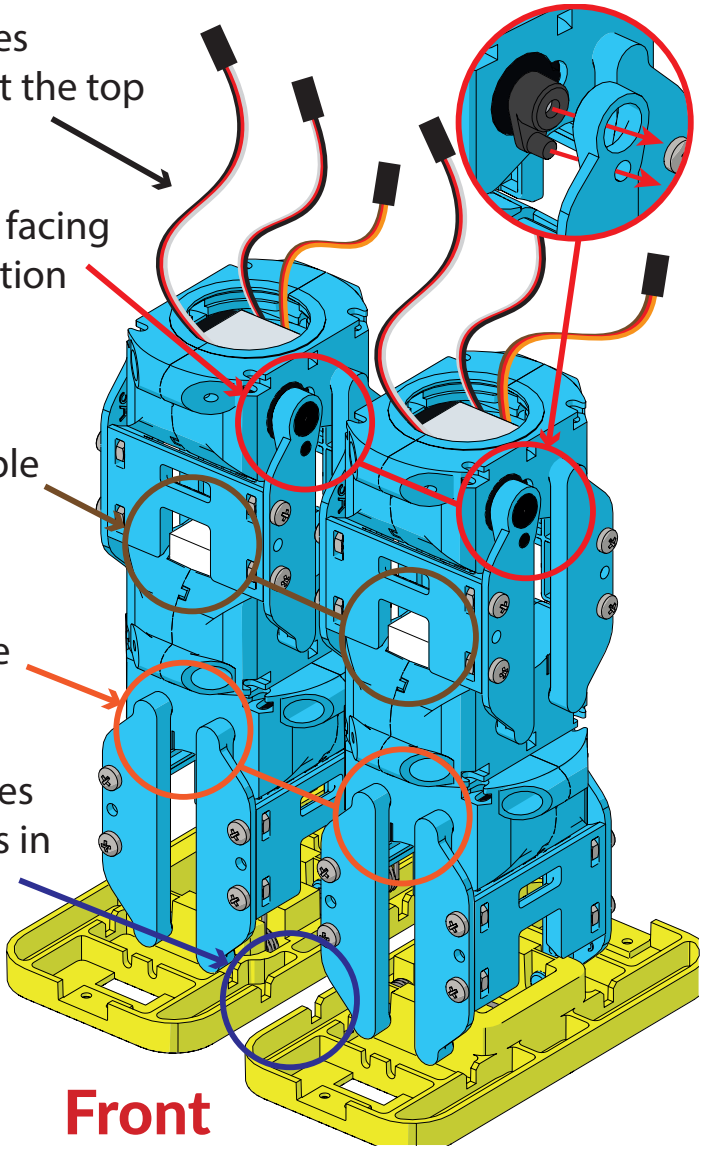

No servo horn visible

Foot notches and springs in the middle



**Front**



-  x 1
-  x 1
-  x 2
-  x 8
-  x 8

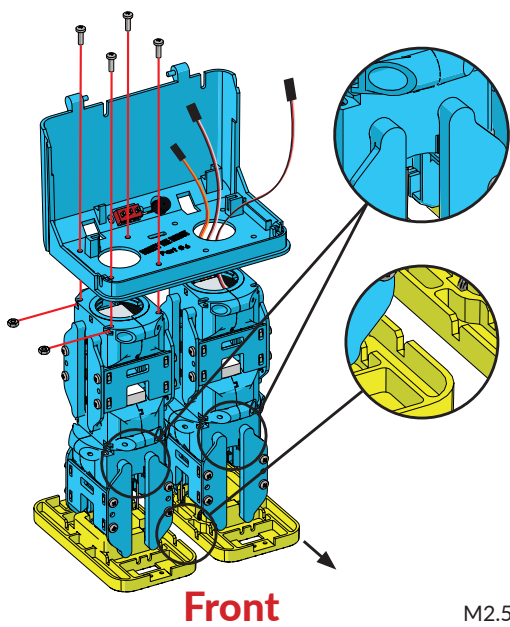

Back

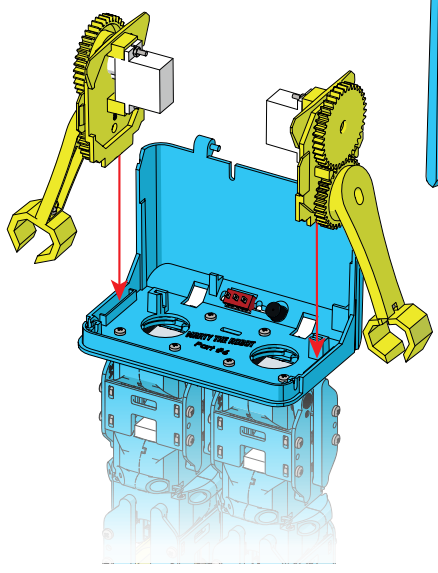
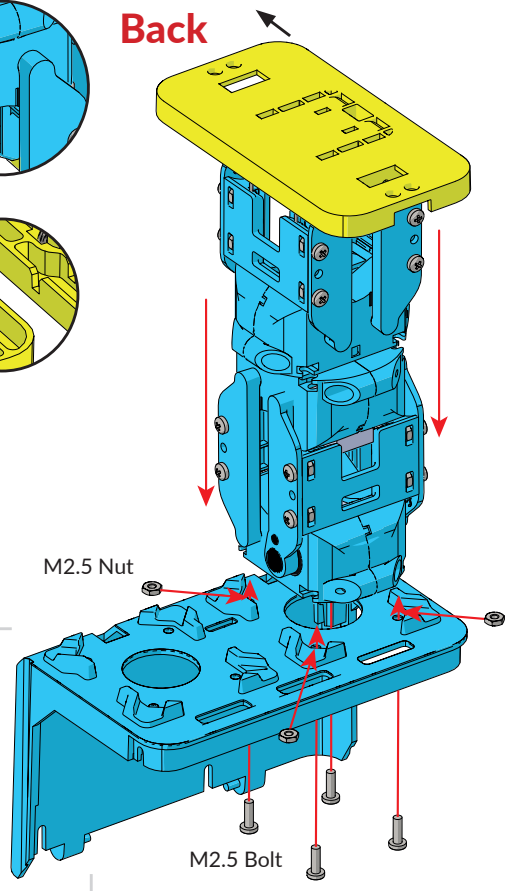

 Legs must be the correct way round. Double check this using the page to the left and graphics above.

21



x 1 Sticker Sheet



x 1

**Attach the head and servo stickers:** attach the numbered stickers to the black servo connectors and clip the two head parts together.

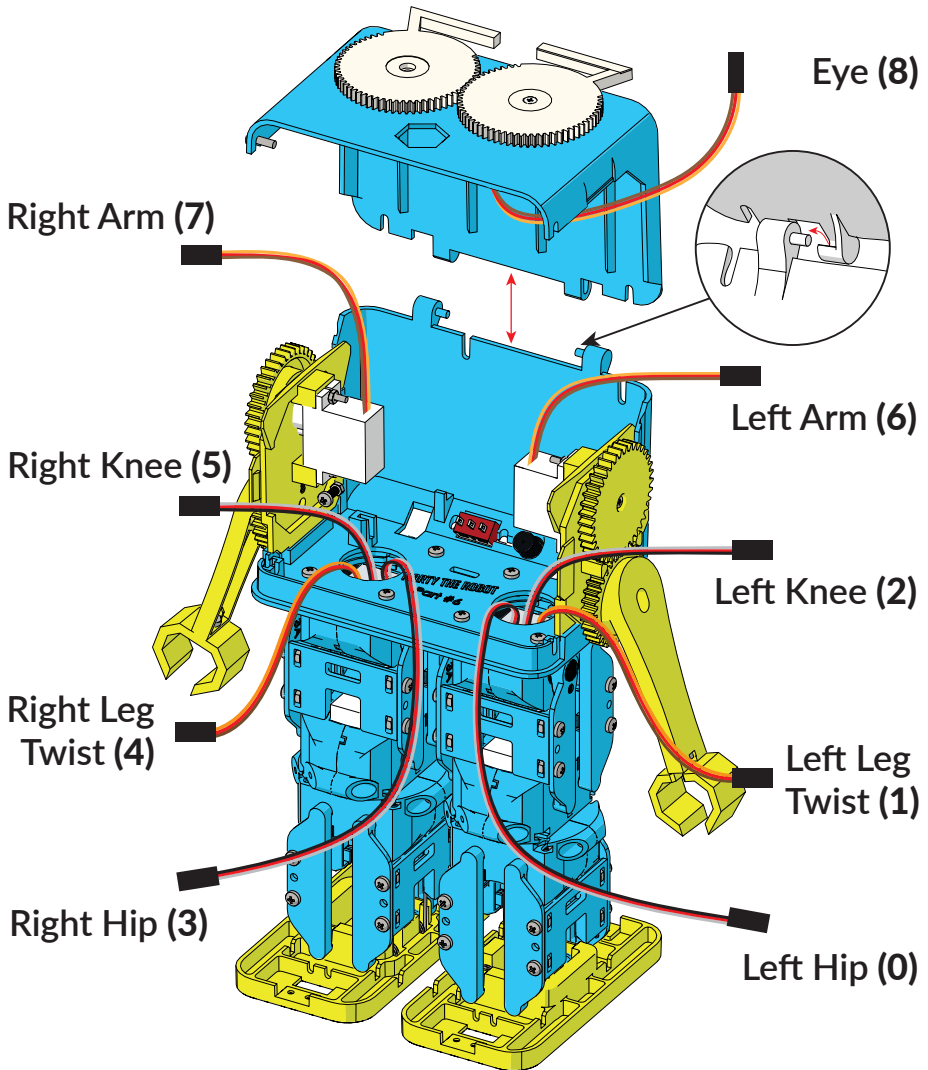

**Top Tip:** the knee/hip servo cables (white & black) will be different lengths if gently pulled straight, the shorter cable is the Knee cable.

22

 x 1

Plug in the Servos: pay attention to the orientation and colour of the cables.

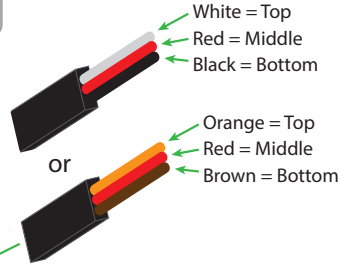
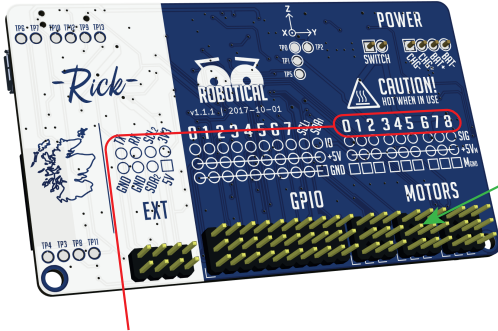

0 = LEFT HIP ●●●

1 = LEFT LEG TWIST ●●●

2 = LEFT KNEE ●●●

3 = RIGHT HIP ●●●

4 = RIGHT LEG TWIST ●●●

5 = RIGHT KNEE ●●●

6 = LEFT ARM ●●●

7 = RIGHT ARM ●●●

8 = EYE ●●●

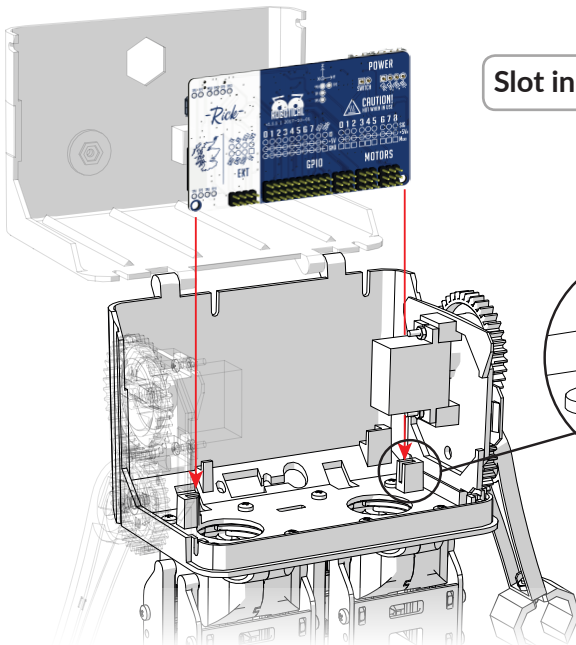

Slot in the control board

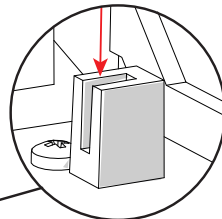

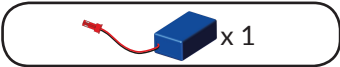

Attach the Battery, ON/OFF Cable and Power Cable:  
read the Safety Warnings on the back of your Parts Guide.

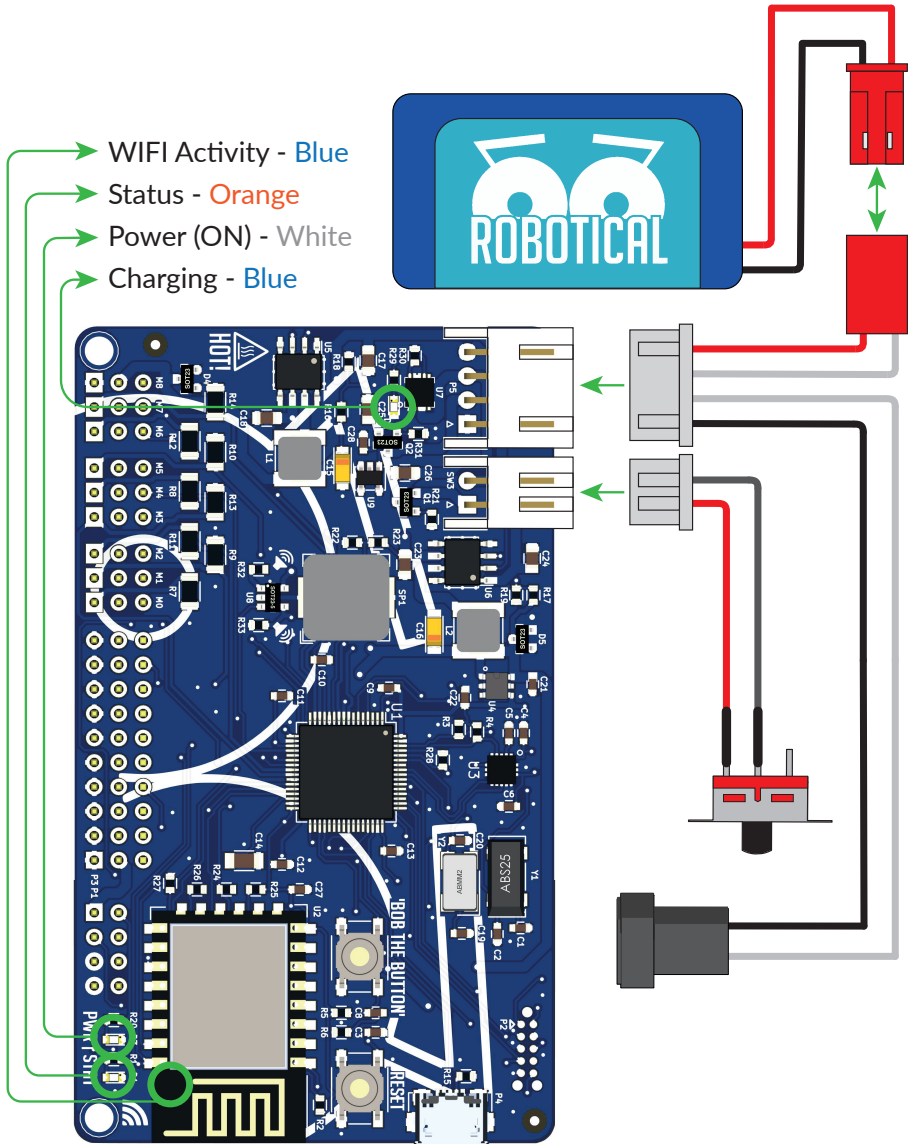

Check the image below - make sure you have all the cables connected and in the correct place.

Place battery securely behind the control board

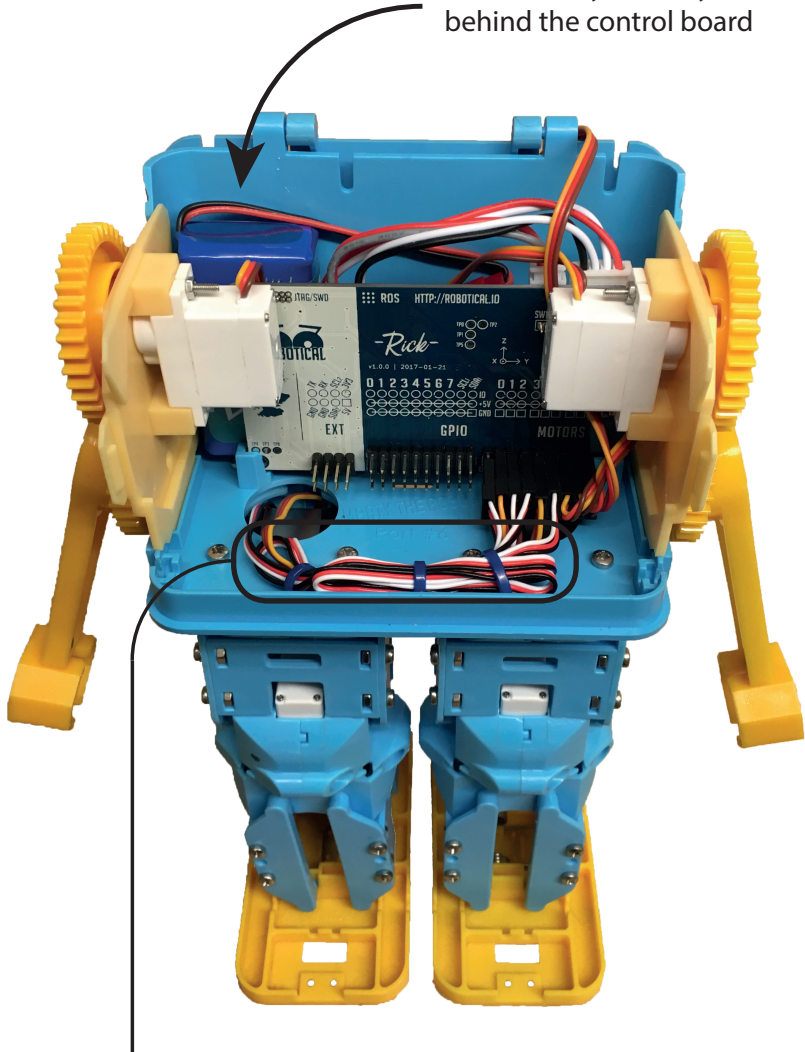

**Optional - Tidy Marty's cables:** using the cable ties provided in your Marty kit, strap the cables down to the base of Marty's head.

24



**Lock Marty's head:**  
using two nuts and  
bolts, lock Marty's  
head to keep all the  
electronics secure.

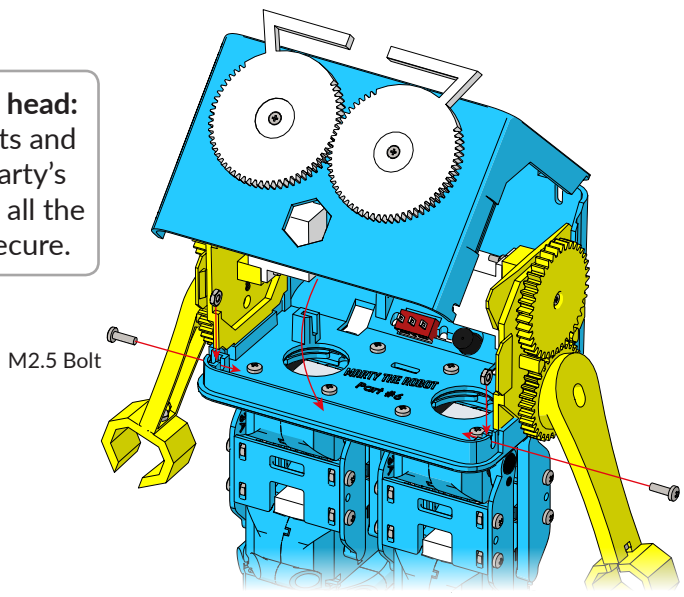

25



Personalise your Marty!

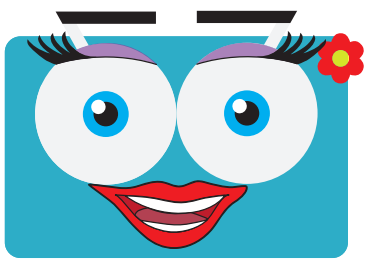
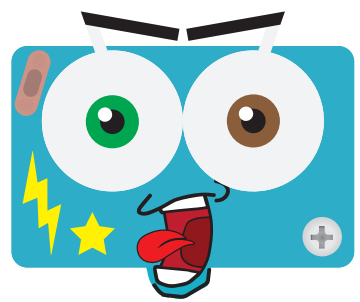
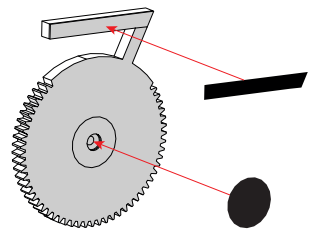

---

# NEXT STEPS!

You have now finished building your Marty!  
To get your Marty up and running go to:

*[robotical.io/setupmarty](https://robotical.io/setupmarty)*

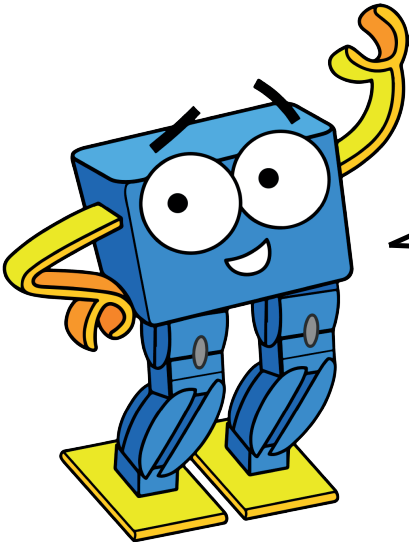

**Great  
job!**

---



# PLAY MARTY FOOTBALL

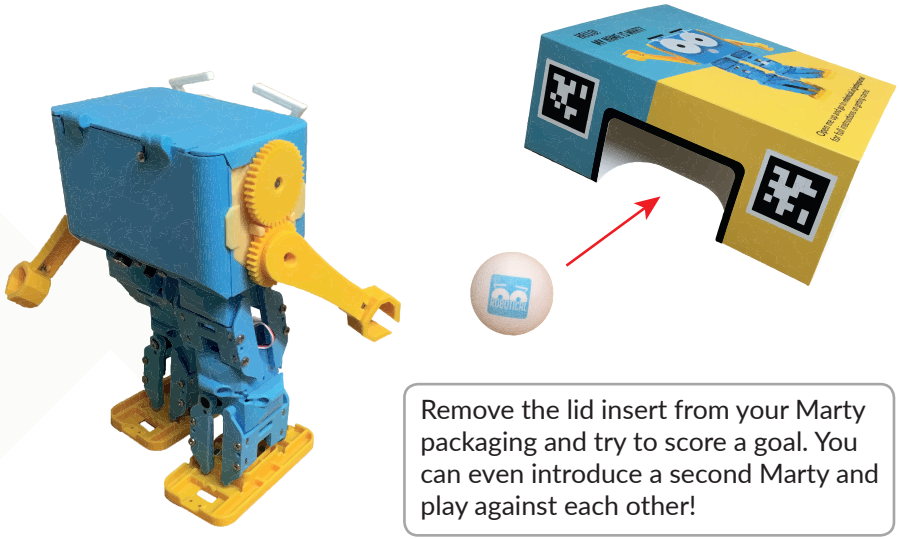

# CONNECT A RASPBERRY PI - OPTIONAL

Raspberry Pi is not included in a standard Marty Kit

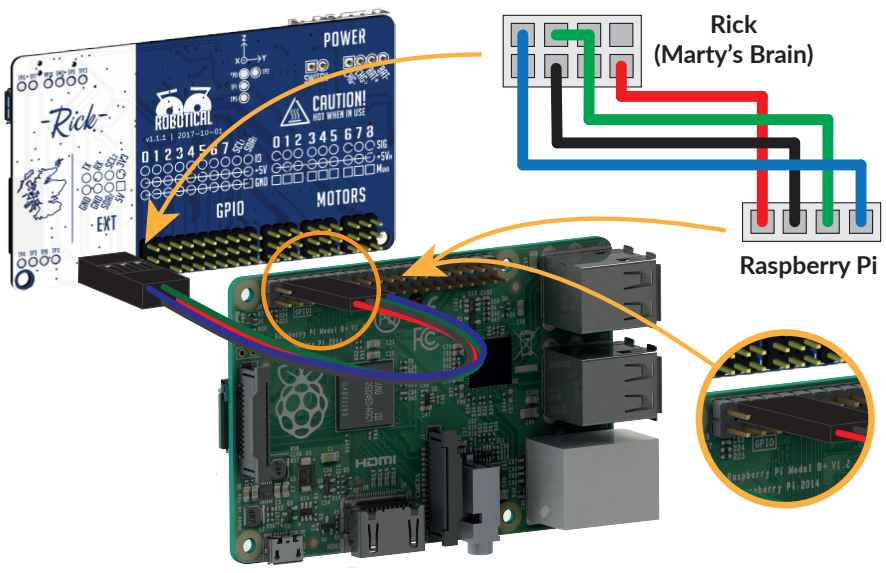

Connect a Raspberry Pi with the cable provided in your Marty pack.

Raspberry Pi is a trademark of the Raspberry Pi Foundation



# PROGRAMMING MARTY

Use and interact with Marty on multiple platforms, with several different programming languages. Go to [robotical.io/getstarted](https://robotical.io/getstarted) for support on the following:

<h2>Scratch</h2>	The simplest way to begin programming your Marty. Combine blocks to build a program to get your Marty up and about.
	Python is a more advanced programming language you can use to control Marty and develop more complex programs.
	You can use Javascript on a webpage to communicate with Marty over a websocket using the JavaScript API.
<h2>Raspberry Pi</h2>	With a Raspberry Pi you can expand your Marty's functionality through the addition of advanced sensors and tools.
	ROS, the Robot Operating System is an amazing set of advanced robotics tools used by industry and academia.

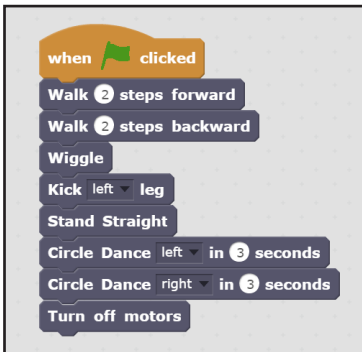

**Scratch**  
(Beginner)

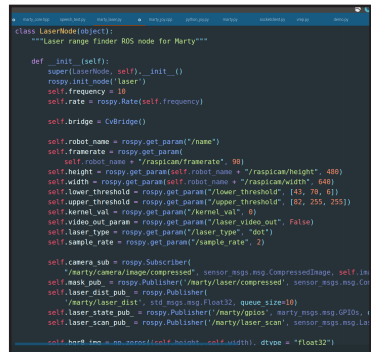

 **python**  
(Intermediate)

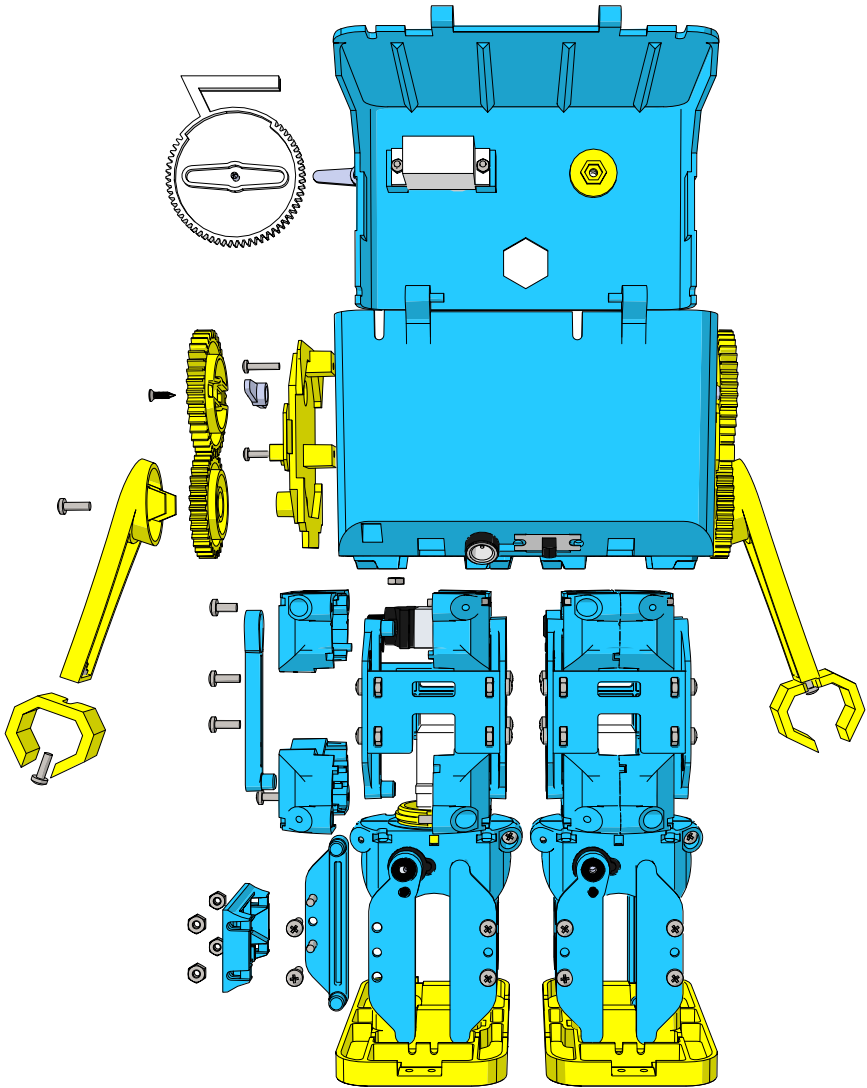

For further help see:  
[robotical.io/gettingstarted](https://robotical.io/gettingstarted)  
[robotical.io/support](https://robotical.io/support)